



Liquid Disposal Bin

OVERVIEW

The easy to use liquid disposal bin allows passengers to empty bottles of their liquid contents before passing through security.

The top features an oval aperture with a plastic funnel that channels the liquids into the removable polyethylene (PE) tank. The plastic funnel includes a strainer to prevent objects from falling into the container.

CONSTRUCTION

Casing Material: 1.4301/AISI 304 stainless steel

Material Thickness: 0.06" (1.5 mm)

Inner Container: Polyethylene (PE)

TOP VIEW

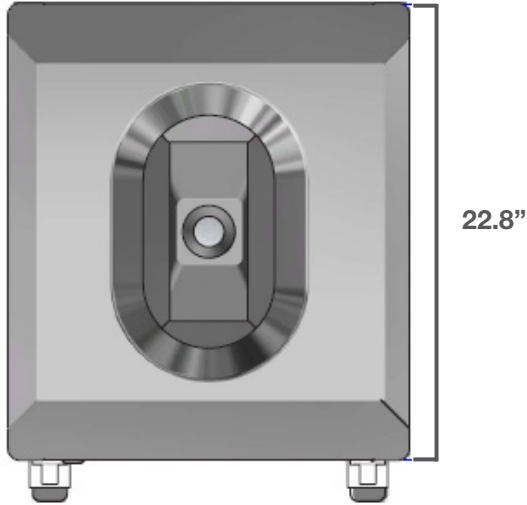

FRONT VIEW

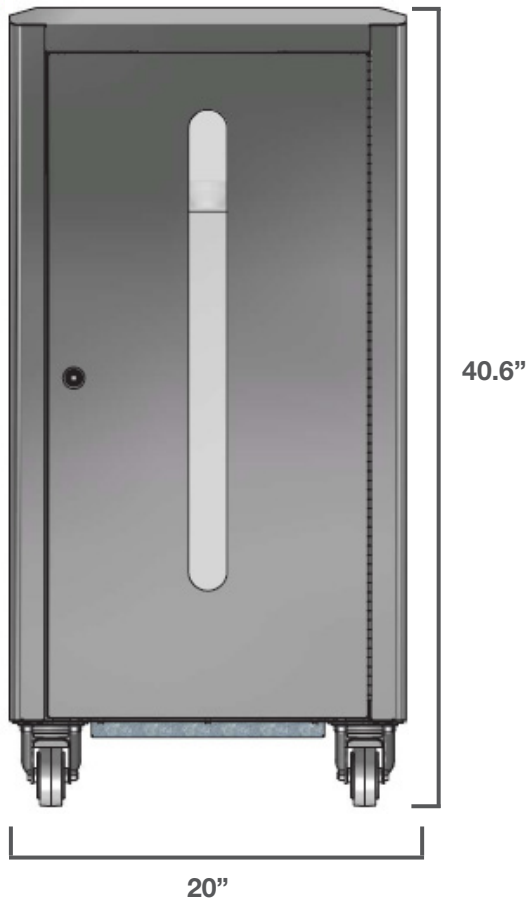

DIMENSIONS

Width: 20" (510 mm)
Depth: 22.8" (580 mm)
Height: 40.6" (1030 mm)

Volume: 13.2 Gal (50 Liters)
Weight: 121.3 lbs (ca. 55 kg)
Slot Size: 6.6" x 11.7" (167 mm x 296 mm)

SAFETY

The material used for the casing of the bin is non-flammable. The PE-tank container is suitable for temporary storage of beverages and is leak-proof. The collected liquid is drained from a faucet attached to the bottom of the tank. The bin-door is equipped with a snap lock and not accessible for unauthorized personnel.

FUNCTION

The door is opened with a provided key and allows for quick and simple removal of the tank or easy access to the attached faucet for emptying. The plastic funnel can be pulled out for cleaning. Wheels are a standard part of this bin to allow easy rolling to the next drainage point.

